

ULT - 200B

BATTERY OPERATED ULTRASONIC LEVEL TRANSMITTER



Features

- Non-contact type
- Compact size & Easy Maintenance
- Easy to Install & Configure
- Process down time minimized
- Automatic Temperature Compensation
- Measures liquid height, distance to liquid, volume or flow in open channels
- Display : LCD
- Password Protection
- Software calibration
- Battery Operated
- Narrow Beam Technology

Description

BRIX series ULT-200B is a Battery Operated Ultrasonic Level Transmitters specially designed for non-contact type level measurement.

Ultrasonic level measurement is based on the transit time technology which calculates the time required by ultrasonic pulses to travel from sensor & surface of liquid & back to sensor. Ultrasonic level transmitters are the best for applications such as slurries, corrosive liquids & waste water without obstacle throughout the beam. The transmitter provides local indication through LCD. The measuring range is available up to 12 mtrs.

Technical Specifications

Measurement Principle	Ultrasonic : Time Of Flight
Measuring Range	up to 12 mtrs.
Communication Output	GSM, GPRS
Power Supply	Battery Operated
Battery Life	2 to 10 Years depending on sampling time
Power Consumption	< 500 mW
Dead Band	Less than 300 mm
Display	LCD
Accuracy	+/- 0.25% of F. S.
Linearity	+/- 0.1%
Repeatability	+/- 0.1%
Stability	+/- 0.05%
Process Temperature	0 to 85°C max.
Operating Pressure	Atmospheric
Beam Angle	< 10°
Measuring Frequency	25 KHz
Temperature Coefficient	+/- 0.01% per °C
Electronic Protection Class	Flameproof (CMRI IIA IIB Certified) / Weather Proof IP-67
MOC Electronics Enclosure	1) Die Cast Aluminium PU Painted 2) SS316 3) ABS Plastic
Process Connection	1) 2" BSP (upto 8 meters) 2) 2.5" BSP (8 to 10 meters) 3) 3" BSP (10 to 15 meters) 4) 4" BSP (15 to 20 meters)
Mounting	Vertical – Top of the tank
Ambient Conditions	Temperature 0 to 85°C / Humidity 5 to 95% non condensing at 25°C
MOC Probe	PVDF
Local Indication Display Type	LCD Display
Certification	CE

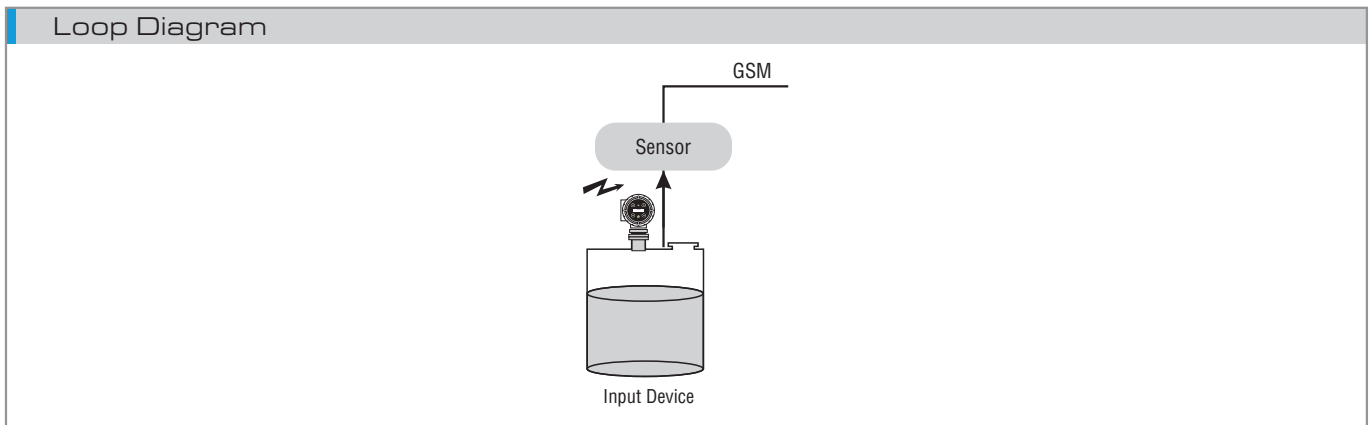
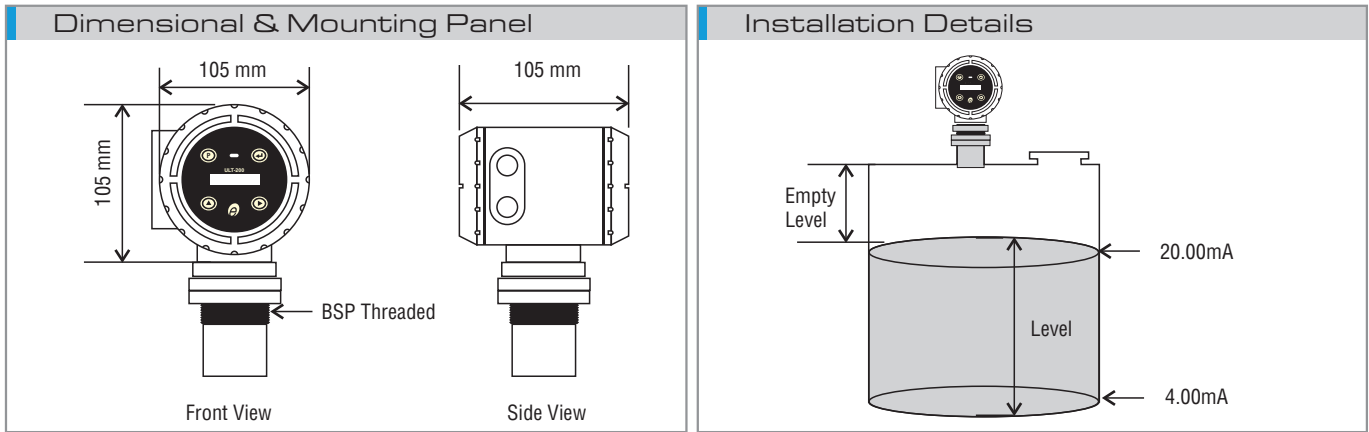

Ordering Information **Sample Order Code :** A3 C1 E1 F1 J1 M3

Parameter	Code	Description	Parameter	Code	Description						
A	Measuring Range	A1	300 mm	E	MOC Electronics Enclosure	E1	Die Cast Aluminium				
		A2	600 mm			E2	SS316				
		A3	1000 mm			E3	ABS Plastic				
		F	Electrical Connection	A4	2000 mm	J	Communication Output 2 (Any one)	F1	M 20 x 1.5 (F)		
				A5	3000 mm			F2	1/2" NPT (F)		
				A6	6000 mm			F3	DIN 43650 / Circular Metal Connector		
				M	Process Connection	A7	8000 mm	M	Process Connection	M2	1 1/2" BSP (M) Threaded
						A8	10000 mm			M3	2 Inch BSP (M) Threaded
						A9	12000 mm			M4	2 Inch PVC Flanged
C	Electronics Area Classification	C1	Field Mount Weather Proof IP67	M5	2 Inch Flanged SS316						
		C2	Flameproof (CMRI IIA IIB Certified)	M6	2 Inch Tri Clover SS316						
D	Power Supply	D1	Battery Operated	Note : <ul style="list-style-type: none"> ▪ Due to our continuous product revisions, design specification and model numbers are subject to change without notice. ▪ Accuracy defined at Lab Conditions. ▪ For other requirement please consult factory. 							
		D2	Solar Operated								