

MAG 200

MAINS / 24V DC POWERED ELECTROMAGNETIC FLOW METER

Features

- Universal Power Supply 90 to 250V AC / 24V DC / Solar Powered
- Suitable for conductive liquids
- Full bore type
- Empty pipe indication
- Material of construction in accordance to process parameters
- Local Indication through LCD Display
- Inbuilt Relay Status output (High / Low / Batch)
- HART Compatible
- Optional pressure measurement along with flow



Description

BRIX series MAG-200 are micro-controller based full bore type electromagnetic flow meters specially used for various industrial applications. These flow meters accurately measure the flow rate of conductive liquids and slurries in closed pipes. Due to its simple and rigid design, the flow meter is an obstruction less and maintenance-free instrument in place of conventional mechanical flow measuring devices. The use of 'Pulsed DC' technology offers highest ability and better measuring accuracy in the form of electrical signal 4-20 mA DC linearly proportional to volumetric flow. The instrument is based on Faraday's law of electromagnetic induction. A magnetic field is generated by the instrument in the flow tube. The fluid flowing through this magnetic field generates a voltage that is proportional to the flow velocity. Corresponding electrical output is provided with respect to measuring flow range.

Technical Specifications

Media	Liquid (Conductive)		
Conductivity	> 5 μ S/cm		
Viscosity	200 cp max		
Line Size	15 NB to 3000 NB		
Excitation	Pulsed DC		
Type of Output	Output : 1 (Any one)	1) 4 to 20mA DC 2) 4 to 20mA DC with HART (Generic)	
	Output : 2 (Any one)	Pulse (Open Collector Type)	
Communication Output	Output : 1 (Any one)	RS485 supporting MODBUS RTU Protocol	
	Output : 2 (Any one)	1) GSM	2) GPRS 3) Ethernet MODBUS TCP
Display	LCD Display - 6 Digit for Flow Rate & 8 Digit for Totalizer Flow		
Engineering Unit	User Programmable (m ³ /hr by default)		
Calibration Range	Wet Calibrated at IEC/ISO/EN17025 Accredited Calibration Laboratory.		
Accuracy	< \pm 0.5% of M.V. + (\pm 5mm /sec) for Velocity Range 0.3 m/s to 6 or 12 m/s		

Linearity	+/- 0.5% of M.V.
Repeatability	+/- 0.2% of M.V.
Temperature Coefficient	+/- 0.05% per °C
Process Temperature	-20 to 85°C max for Rubber Lining & -20 to 220°C for PTFE Lining
Process Pressure	16 kg/cm ² max (Higher on request)
Material of construction	1) Lining – Neoprene / Ebonite Rubber, PFA, PTFE, PU, CERAMIC
	2) Flange – MS, CS, SS316, SS304
	3) Electrode – SS316L, Hastelloy C, Platinum, Tantalum, Titanium
	4) Coil Housing – MS, SS304, SS316
Power Supply	Option 1 : 90 – 250 V AC, 50 Hz
	Option 2 : 24 V DC (+/- 10%)
	Option 3 : Solar Powered 24V DC
Power Consumption	< 10 VA
Isolation	1.4 KV between Input, Output & Power Supply
Response Time	Less than 1 Sec.
Electronics	Integral (Local) / Remote
Electronic Protection Class	Field Mount Weather Proof IP-67, Field Mount Weather Proof IP-68, DIN Standard (IP 54), Flameproof (CMRI IIA IIB Certified)
Sensor / Flow Tube Protection class	Weather Proof IP-67, IP-68
Process Connections	ANSI150 flanged, as per table B 16.5 (Other On Requirement)
Mounting	In-Line Horizontal / Vertical
Ambient Conditions	Temperature -20 to 75°C / Humidity 5 to 95% non condensing
Certification	CE

Assembly Overview

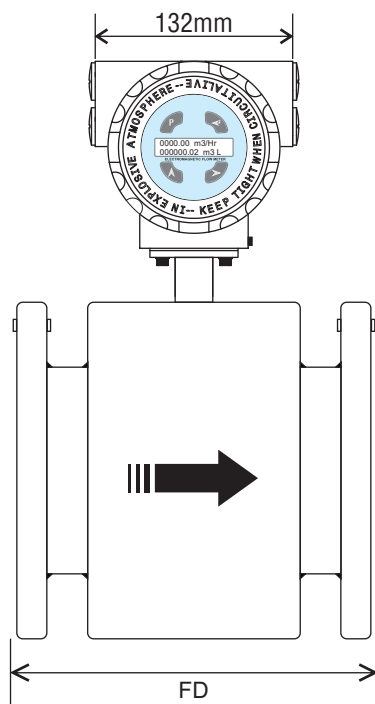

Fig. 1 Front View

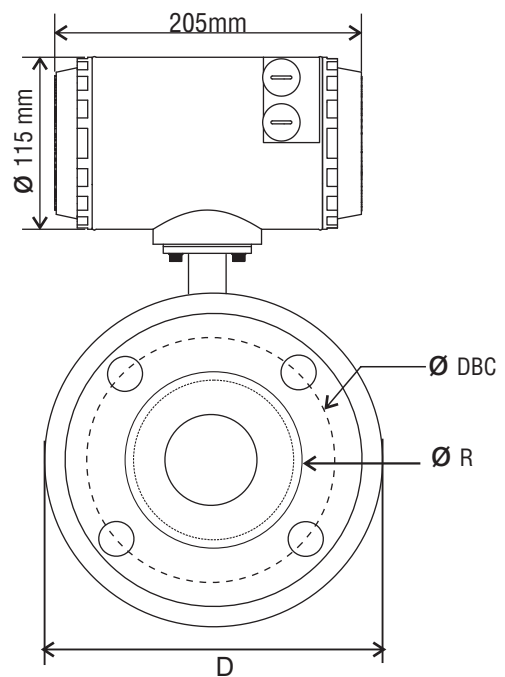

Fig. 2 Side View

TABLE : Dimensional Details (Flow Meter with ANSI 150 Flange)

Refer Drg. Fig.1 & 2

Line Size Inch	NB	Flange Diameter D (mm)	Diameter of Raised Face R (mm)	Diameter of Bolt Hole Circle DBC (mm)	Diameter of Bolt Hole (mm)	No. of Holes	Thickness of Flange	Housing OD (mm)	Flange to Flange Distance (FD) (mm)	Flow Range (m ³ /hr) for Velocity 0.3m/s to 6m/s	
										Min.	Max.
1/2"	15	88.9	34.9	60.3	15.9	4	11.1	125	200	0.19	3.817
3/4"	20	98.4	42.9	69.8	15.9	4	12.7	125	200	0.33	6.785
1"	25	107.9	50.8	79.4	15.9	4	14.3	145	200	0.53	10.602
1 1/4"	32	117.5	63.5	88.9	15.9	4	15.9	155	200	0.86	17.371
1 1/2"	40	127.0	73.0	98.4	15.9	4	17.5	155	200	1.35	27.143
2"	50	152.4	92.1	120.6	19.0	4	19.0	165	200	2.12	42.4115
2 1/2"	65	177.8	104.8	139.7	19.0	4	22.2	185	200	3.58	71.675
3"	80	190.5	127.0	152.4	19.0	4	23.8	205	200	5.42	108.573
4"	100	228.5	157.2	190.5	19.0	8	23.8	245	260	8.48	169.646
5"	125	254.0	185.7	215.9	22.2	8	23.8	265	260	13.25	265.071
6"	150	279.4	215.9	241.3	22.2	8	25.4	285	310	19.085	381.703
8"	200	342.9	269.9	298.4	22.2	8	28.6	355	360	33.929	678.584
10"	250	406.4	323.8	361.9	25.4	12	30.2	405	460	53.014	1060.28
12"	300	482.6	381.0	431.8	25.4	12	31.8	485	510	76.340	1526.81
14"	350	533.4	412.7	476.7	28.6	12	34.9	555	562	103.908	2078.16
16"	400	596.9	469.9	539.7	28.6	16	36.5	605	612	135.716	2714.33
18"	450	635.0	533.4	577.8	31.7	16	39.7	605	612	171.766	3435.33
20"	500	698.5	584.2	635.0	31.7	20	42.9	630	612	212.057	4241.15
24"	600	812.8	692.1	749.3	34.9	20	47.6	755	612	305.362	6107.25

Note : Flange to flange distance (FD) Tolerance : 1) 1/2"(15NB) to 6"(150NB) : +/-3mm 2) 8"(200NB) to 24"(600NB) : +/-5mm

- All dimensions are in 'mm'
- For dimensions of line size above 600NB, please consult factory.
- Typical mounting dimensions are for reference only.
- Wet Calibrated at IEC/ISO/EN17025 Accredited Calibration Laboratory.
- Flow meter should be selected with the help of Nomograph (recommended full scale velocity).
- Flow indication of 6 digit max. up to 999999.

Flow Nomograph

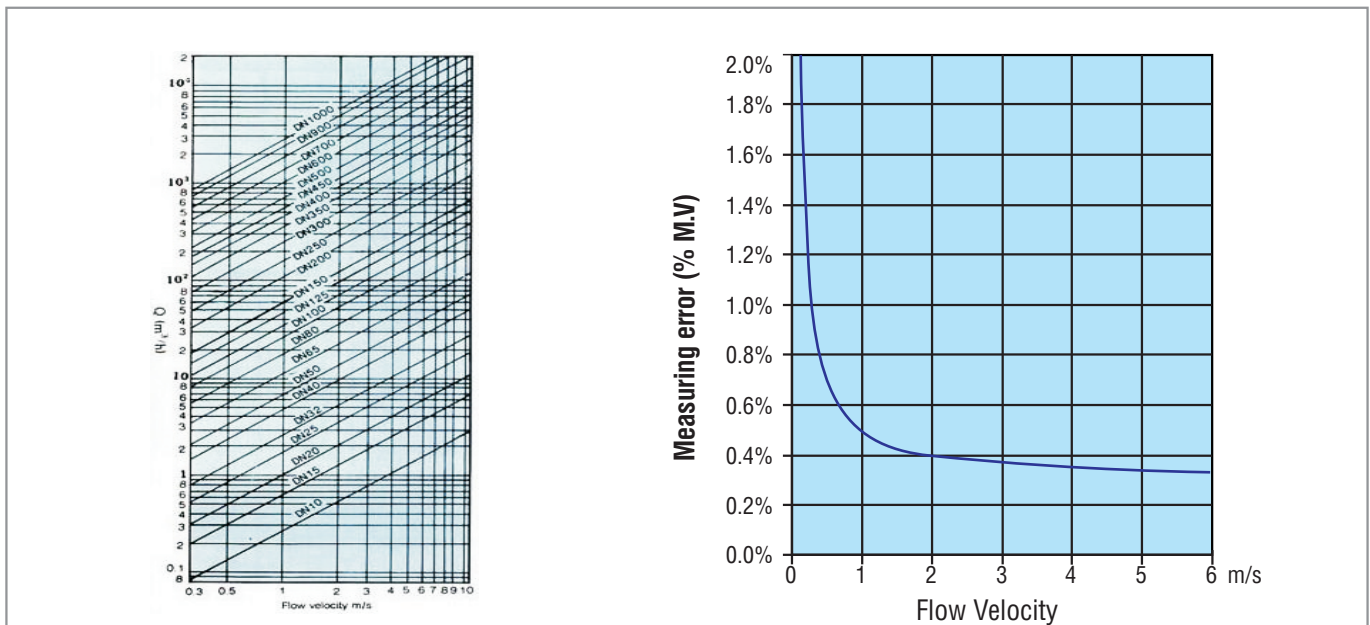

Applications

Food Industry	Chemical Industry	Atomic Energy	Manufacturing Industry
Automation Industry	Thermal Power Energy	Process Industry	Water Treatment Industry

Product Ordering Information :

Order Code for Flow Transmitter

Sample Order Code : TX 1 A2 B2 C1 D2 EX F2 GX HI I2

Parameter	Code	Description	
TX	Electronics Transmitter	TX 1	Field Mount Weather Proof IP67
		TX 2	Field Mount Weather Proof IP68
		TX 3	DIN Standard (IP 54)
		TX 4	Flameproof (CMRI IIA IIB Certified)
A	Power Supply	A1	90 to 250 VAC
		A2	24V DC
		A4	Solar Powered 24V DC
B	MOC Electronics Enclosure	B1	Aluminium Die Cast
		B2	SS316
C	Electrical Connection	C1	M20 *1.5 F
		C2	1/2 Inch NPT F
		CY	Other
D	Output 1 (Any One)	D1	4 to 20 mA
		D2	4 to 20 mA HART (Generic)
		DX	NA
E	Output 2 (Any One)	E1	Pulse (Open Collector Type)
		EX	NA

Parameter	Code	Description	
F	Alarm or Relay Output	F1	1 Relay Output
		F2	2 Relay Outputs
		FX	NA
<i>(maximum two alarms or two Relays)</i>			
G	Communication Output 1 (Any One)	G1	RS485 (MODBUS RTU)
		GX	NA
H	Communication Output 2 (Any One)	H1	GSM
		H2	GPRS
		H4	Ethernet MODBUS TCP
		HX	NA
I	Process Pressure Calibration Range	I1	10 Kg
		I2	20 Kg
		IX	NA

Note :

- In case of flameproof version only electronics enclosure is flameproof certified.
- Accuracy defined at Lab Conditions.
- Relay & Alarms are programmable. Relay 1 is programmable for High / Low / Batch.

Order Code for Flow Tube

Sample Order Code : FT 15 J2 K2 L1 M2 N1 O3 P1 Q1 R2 S1 U1

Parameter	Code	Description	Code	Description	Parameter	Code	Description		
FT	Flow Tube	FT 15	15 NB	FT 600	600 NB	O	Material of construction – Coil Housing	O1	MS
		FT 20	20 NB	FT 700	700 NB			O2	SS304
		FT 25	25 NB	FT 800	800 NB			O3	SS316
		FT 32	32 NB	FT 900	900 NB	P	Flow Tube Lining Material	P1	Neoprene Rubber (Above 40 NB)
		FT 40	40 NB	FT 1000	1000 NB			P2	Ebonite Rubber (Above 40 NB)
		FT 50	50 NB	FT 1100	1100 NB			P3	PFA (15 to 300 NB)
		FT 65	65 NB	FT 1200	1200 NB			P4	PTFE (15 to 600 NB)
		FT 80	80 NB	FT 1400	1400 NB			P5	PU (15 to 400 NB)
		FT 100	100 NB	FT 1500	1500 NB			P6	Ceramic (15 to 600 NB)
		FT 125	125 NB	FT 1600	1600 NB			PY	Other
		FT 150	150 NB	FT 1800	1800 NB	Q	Flange Standard and Rating	Q1	ANSI 150 B16.5
		FT 200	200 NB	FT 2000	2000 NB			Q2	ANSI 300 B16.5
		FT 250	250 NB	FT 2200	2200 NB			Q3	ANSI 600 B 16.5
		FT 300	300 NB	FT 2400	2400 NB			Q4	DIN PN 10 EN 1092-1
		FT 350	350 NB	FT 2600	2600 NB			Q5	DIN PN 16 EN 1092-1
		FT 400	400 NB	FT 2800	2800 NB			Q6	DIN PN 25 EN 1092-1
		FT 450	450 NB	FT 3000	3000 NB			Q7	DIN PN 40 EN 1092-1
		FT 500	500 NB					Q8	IS 1538
								Q9	AWWA Table D
								Q10	AWWA Table F
J	Electronics Location	J1	Integral (Local)	R	Material of construction – Flow Tube	R1	SS304		
		J2	Remote			R2	SS316		
K	Remote Cable Length	K1	5 Meter			RY	Other		
		K2	10 Meter			S	Material of construction – Electrode	S1	SS316L
		K3	15 Meter					S2	Hastelloy C
		K4	25 Meter	S3	Platinum				
		KX	NA	S4	Tantalum				
L	Flow Tube Protection Class	L1	IP-67 (In case of Integral)	S5	Titanium				
		L2	IP-68 (In case of Remote)	U	Inline Pressure Sensor	U1	10 Kg		
M	Process Connection	M1	Threaded (15 to 50 NB)			U2	20 Kg		
		M2	Flanged (15 To 3000 NB)			UX	NA		
		M3	Triclover (15 to 100 NB)	N	Material of construction – Flange	N1	MS		
		M4	SMS Union (25 to 100 NB)			N2	CS		
		M5	Compact (Wafer) – 15 to 200 NB Maximum			N3	SS304		
		N4	SS316						
		NX	NA						

Note :
 ▪ Due to our continuous product revisions, design specification and model numbers are subject to change without notice.
 ▪ To be used for industrial applications.
 ▪ For other requirement please consult factory.